

SINGER
21W4

Form 750 w
April 30, 1909

PRICE LIST

OF

PARTS



Trade Mark

21 w 4

MACHINE

THE SINGER MANUFACTURING CO.

Instructions for Ordering

INDEX

	Page
Accessories	S, 9, 10
Bobbin Winder.....	9
Knee Lifter Parts.....	5, 10
Numerical List of Parts.....	13
Under Driver.....	H, 12

In ordering from this list, use **ONLY** the **PART** number in the **FIRST** column.

The number stamped on a Sewing Machine Part is the number of the Single Part only, except when the part includes Set Screws, Clamping Screws, Studs and Rollers, Span on, Small Wires, riveted, or Parts soldered together, etc., which it is necessary to furnish in combination.

Every combination of parts sent out has its specific number which, although not stamped on Parts (except in above cases) must be used when ordering the combination.

Each number always indicates the **SAME PART** in whatever list it appears, or for whatever Machine.

The letters after some of the numbers indicate the style of finish only, as follows:

- A. Hardened, Polished and Plated.
- B. Polished and Plated.
- C. Hardened only.
- D. Polished only.
- E. Soft, not polished.
- F. Hardened and Polished.
- H. Blued.

These letters **MUST BE USED** when they appear in the list and **AFTER** the number, as in the list.

In this series

200001 to 201500 are Screw Numbers.

201501 to 201800 are Nut Numbers.

201801 to 202000 are Roller Numbers.

202001 and upward are numbers of Machine Parts.

The figures in the second column refer only to the plate in which the illustration of the part is shown and are **NOT TO BE USED** in ordering.

Two or more numbers over a cut indicate that the difference between such parts is not visible in an illustration.

Parts marked with an asterisk (*) are furnished only when repairs are made at the factory.

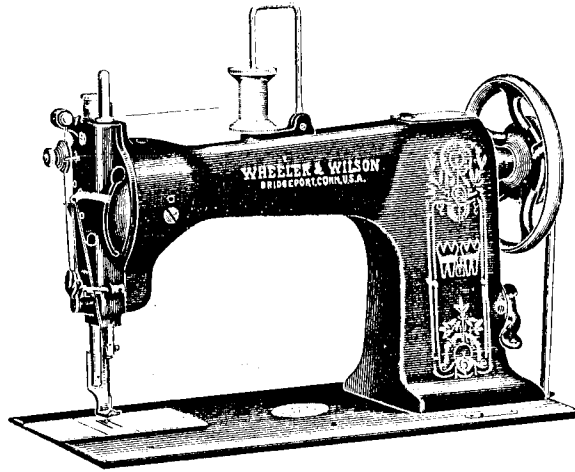

No. 21 w4 MACHINE

OUTFIT No. 203253

(Formerly "No. 2" Outfit)

DROP FEED, BOBBIN No. 203208 (formerly "4")

For General Cloth Work, Shirts, Underwear, Shirt Waists,
Wrappers, Corsets, etc.

No.	Plate	Name	Each
*204161	----	Arm	75
*204412	----	" 204161 with 200439c, 202036 and 204705	1 75
204163	12305	" Cap	10
200278n	12311	" " Screw	05
202248n	12307	" " Washer	05
200016E	12311	" Screw (3)	06
202005	12308	" " Washer (3)	01
203202	12301	" Shaft	1 75
204705	12304	" " Bushing (front)	35
200439c	12311	" " " Position Screw	05
204165	12302	" " Connection with 204166, 204167 and four 200054E, (2)	75
*204166	----	" " " Cap (lower)	75
*204167	----	" " " " (upper)	75
200054E	12307	" " " " Screw	03
202239	12306	" " Oil Packing (wick)	01

No.	Plate	Name	Each
203204	12301	Balance Wheel 5½ in. diameter (bolt groove 2¼ in. diameter) with 200328c and 200335c.....	1 00
200062n	12311	Balance Wheel Adjusting Screw.....	07
200328c	12311	" " Position Screw.....	01
200335c	12311	" " Set Screw.....	01
*203205	----	Bed	—
*203310	----	" 203205 with 202062, 203218, 203219, two each 200362c, 200516c, 200810c and 202299	5 25
202258	12315	Bed Hinge Connection (2).....	08
200570c	12311	" " " Screw (1).....	05
203206	12302	" Slide (back).....	30
203207	12302	" " (front)	25
203208	12312	Bobbin (formerly "F").....	05
203210	12312	" Case Base with 202056, 203211 to 203213 and 203216	55
203211	12312	" " " Latch	05
202056	12312	" " " " Pin	01
203212	12312	" " " " Plunger	02
203213	12312	" " " " Spring	01
203209	12312	" " Cap with 200593c, 203211, 203215 and two 200594c	25
203214	12312	" " Tension Spring (formerly "F")	05
200593c	12312	" " " Spring Regulating Screw	02
200594c	12312	" " " " Screw	02
203215	12312	" " Thread Guide	03
200594c	12312	" " " " Screw	02
203216	12312	" " Washer (cloth) per 100.....	25
203217	12312	Bobbin Case complete, Nos. 203209 and 203210	80
200459n	12306	Cloth Guide Thumb Screw.....	10
204184	12301	Face Plate with 200366n, 200368n, 202099, 204185, 204281 and two 200385n	75
200053c	12311	" " Screw	01
204185	12310	" " Thread Guide.....	03
200385n	12309	" " " " Set Screw.....	02
204186	12301	Face Plate complete, Nos. 200365c, 200369c, 200319c, 200577n, 204059, 204184, 204267, 204272 and 204277 to 204280	2 40
203218	12302	Feed Bar with 204189.....	40
229799	----	" " 203218 with 200214c, 201525c, 204200, 211079 and two 200106c	1 35
200214c	12310	" " Hinge Screw.....	12
201525c	12310	" " " Nut	03
204188	12310	" " Spring	03
204189	12306	" " " Hook	01

No.	Plate	Name	Each
211079	12314	Feed Dog (formerly "A") for general muslin work and hemming, for 211077	40
200106c	12314	Feed Dog Screw.....	02
203233	12305	" Driving Cam (formerly "V-II") with 200378c and 200437c	50
204192	----	" " " Fork lever	70
204193	12302	" " " " Connection with 200668c and 201525c	35
204194	12306	" " " Fork-lever Connection Clamp with 200031c	45
200031c	12314	" " " Fork-lever Connection Clamp Pinch Screw	04
200668c	12310	" " " Fork-lever Connection Clamp Screw Stud	06
201525c	12310	" " " Fork-lever Connection Clamp Screw Stud Nut	03
200002c	12310	" " " Fork-lever Connection Hinge Screw	07
201522c	12310	" " " Fork-lever Connection Hinge Screw Nut	03
204195	----	" " " Fork-lever Shaft.....	15
204197	12306	" " " " " Collar with 200113c	15
200113c	12308	" " " " Shaft Collar Set Screw	03
204293	12308	" " " " Shaft Position Pin	01
204196	12307	" " " " " Sleeve (split)	25
200043c	12314	" " " " " Sleeve Set Screw	01
201521c	12310	" " " " " Sleeve Set Screw Nut	03
204198	12304	Feed Driving Cam Fork-lever complete, Nos. 204192, 204194, 204195 and 204293	1 30
200437c	12314	Feed Driving Cam Position Screw.....	06
200378c	12314	" " " Set Screw.....	02
204199	12301	" " Rock Shaft.....	35
206551	----	" " " " 204199 with 200002c, 201522c and 204193	80
202305c	12307	" " " " Center (2).....	06
200043c	12314	" " " " " Set Screw (2)	04
204200	12305	" " " " Crank with 204189 (on left side) and two 200383c	35
204189	12306	" Driving Rock Shaft Crank Spring Hook	01
200383c	12314	" " " " " Set Screw	02

No.	Plate	Name	Each
203235	12308	Feed Lifting Cam (formerly "2") with 202126	75
204202	12308	" " " Fork with 200027c....	75
200027c	12310	" " " " Pinch Screw....	04
202126	12308	" " " " Position Pin.....	01
200045c	12310	" " " " Screw	02
203236	12301	" " " Rock Shaft	25
203316	12301	" " " " 203236 with 203238	60
202305c	12307	" " " " Center (2).....	06
200043c	12311	" " " " " Set Screw (2)	04
202276	12308	" " " " Slide Block.....	15
203238	12308	" " " " " " 202276 with 200243c and 201531c	35
200243c	12310	" " " " Shaft Slide Block Hinge Screw	08
201531c	12308	" " " " " " Hinge Screw Nut	03
204206	12306	" Regulating Handle.....	10
204207	12304	" " " 204206 with 200098c, 202622, 201208 to 201210 and 201213	55
204208	12307	" Regulating Handle Adjustable Stop	05
200098c	12307	" " " " Stop Screw	03
204209	12307	" " " " Position Pin.....	01
204210	12306	" " " " Shaft	20
204211	12306	" " " " Crank with 200078c	20
204212	12307	" " " " " Link ..	15
200271c	12311	" " " " " Link Hinge Screw (lower)	05
200291c	12307	" " " Handle Shaft Crank Link Hinge Screw (upper)	05
200078c	12307	" " " " Shaft Crank Set Screw	03
204213	12307	" " " " Sleeve (split)...	15
200362c	12311	" " " " " Set Screw...	02
202622	12306	" " " " " Washer ...	01
202036	12310	" " " " Stop Pin.....	01
204214	---	Feed Regulating Handle complete, Nos. 200291c, 204207, 201211 and 201212....	95
203239	---	Hook (sewing).....	---
203240	12312	" 203239 with 200500c, 200616c and 203251	2 20
203290	12312	Hook and Bobbin Case complete, Nos. 203217 and 203240	3 00
203241	12312	" bevel Gear-socket, 24 teeth.....	85
200555u	12312	" " " Screw	05
203242	12305	" " Pinion, 24 teeth, with two 200383c	1 00
200383c	12311	" " " " Set Screw.....	02

No.	Plate	Name	Each
203243	12302	Hook Counter-shaft.....	10
203244	12308	" " Collar with two 200393c....	20
200393c	12308	" " " " Set Screw.....	02
203245	---	" " Driving Gear, 44 teeth, with 200362c and 200439c	1 00
213154	12305	" " Driving Gear 203245 with 200045c and 203235	1 80
200439c	12311	" " " Gear Position Screw	05
200362c	12311	" " " " Set Screw.....	03
203246	12305	" " Gear, 22 teeth, with two 200383c	75
200383c	12311	" " " " Set Screw.....	02
202299	12306	" " Oil Packing (wick) (2)...	01
200810c	12311	" " " " (wick) Stop Screw (2)	10
203247	12304	" Driving Shaft	1 60
203248	12304	" " " Bearing with 202299...	20
202299	12306	" " " " Oil Packing (wick)	01
202126	12308	" " " " Position Pin.....	01
200516c	12311	" " " " Screw (2).....	08
203249	12305	" " " Bushing (eccentric)...	25
200362c	12311	" " " " Set Screw.....	03
202299	12306	" " " " Oil Packing (wick)	01
203250	12308	" " " Collar with two 200393c	20
200393c	12308	" " " " Set Screw.....	02
203251	12312	" Gib	40
200600c	12312	" " Hinge Screw.....	02
200616c	12312	" " Screw	02
203252	12313	" Saddle with 202299.....	1 00
202299	12306	" " Oil Packing (wick).....	01
200006c	12307	" " Screw (2).....	07
225585c	12307	" " " Washer (2).....	02
203254	12312	" Washer with 203255.....	20
203255	---	" " Pin	01
203253	12313	Hook Saddle complete, Nos. 200555u, 203241, 203252, 203254 and 203290....	5 00
202445	12317	Knee Lifter Connection Lever with 202446 227311	07
200224u	12306	" " " " 202445 with 200224u, 200262u, 227302 and 227308	50
200224u	12306	" Lifter Connection Lever Hinge Screw	12
227308	12317	" " " " Lifting Rod with 202302	05
202302	12306	" " " Lever Lifting Rod Cotter Pin	01
202446	12306	" " " " Pin	03
227302	12317	" " Lifting Lever	10
200262u	12306	" " " " Hinge Screw....	10

No.	Plate	Name	Each
204247	12304	Needle Bar (hollow) with 200125c, 200175e and 204250	80
204248	12307	" " Connecting Link.....	35
200658c	12307	" " " " Hinge Screw Stud	10
201519e	12307	" " " " " Screw Stud Nut	03
204249	12308	" " " " Stud with 200072c and 202330	40
202330	"	" " " " Oil Packing (wick)	01
200072c	12308	" " " " Pinch Screw	03
200504e	12310	" " Screw Bushing (lower).....	05
200503b	12310	" " " " (upper).....	05
204326	12306	" " " " Packing Cord (2) per 100	25
204250	12308	" " Thread Guide.....	03
200175e	12308	" " " " Set Screw.....	02
200125c	12308	" " Set Screw.....	02
204251	12304	Presser Bar (hollow) with 200041d.....	80
204252	12308	" " Lifter.....	20
200550c	12311	" " " Hinge Screw.....	08
204253	12308	" " Lifting Bracket with 200086c	40
200086c	12308	" " " " Pinch Screw..	03
204254	12307	" " " " Position Guide	30
200362c	12311	" " " " Guide Set Screw	03
204327	12306	" " Packing Washer (felt) per 100	25
200504e	12310	" " Screw Bushing (lower).....	05
204255	12310	" " Spring.....	10
200491b	12305	" " Thumb Screw (pressure re- gulating)	25
229851	12314	" Foot for 211079.....	15
200074d	12308	" " Screw.....	03
202068	12315	Spool Holder Base.....	15
200575h	12311	" " " Screw.....	05
204296	12315	" " Wire.....	10
200079h	12311	" " " Hinge Screw.....	02
204297	12315	Spool Holder complete, Nos. 200079h, 202068 and 204296	25
212920	---	Take-up Cam (formerly "V-3") with 200335c and 200436c	1 35
203268	12304	" " 212920 with 200383c, 200658c and 201519e	1 50
202325	12307	" " Friction Washer.....	05
200430c	12311	" " Position Screw.....	08
200383c	12311	" " " " Check Screw	02
200335c	12311	" " Set Screw.....	04

No.	Plate	Name	Each
203270	12310	Take-up Lever (formerly "X") with 201265	60
203291	12310	" " 203270 with 204263.....	75
204263	12310	" " Bearing with 204264.....	15
204264	12306	" " " Position Pin.....	01
200042e	12311	" " " Screw.....	05
*201265	-----	" " Oil Guard.....	05
201816	12307	" " Roller.....	12
203271	-----	Take-up Lever (formerly "X") complete, Nos. 200042e, 201816 and 203291	90
202402	12309	Tension Disc (2).....	05
202090	12309	" " Position Pin.....	01
204267	12310	" Release Lever.....	05
200309e	12309	" " " Screw.....	04
202075	12309	" Plunger.....	03
204268	12310	" " Slide with 204269.....	20
204269	12308	" " Slide Spring.....	02
202407	12309	" Spring.....	05
200632b	12309	" Stud.....	20
200385h	12309	" " Set Screw.....	02
201572b	12309	" Thumb Nut.....	04
204271	12309	" Washer.....	05
204272	12309	Tension complete, Nos. 200632b, 201572b, 202075, 202407, 204271 and two 202402	50
204273	12308	Thread Controller Adjusting Collar with 200684h (for Presser Bar)	15
200684h	12308	" " Adjusting Collar Screw...	04
204274	12309	" " Plate.....	12
200577h	12311	" " " Screw.....	02
202098	12309	" " Roller.....	05
204275	12309	" " Guard.....	10
202084	12309	" " " Washer.....	01
200300h	12309	" " " Screw.....	04
204276	12309	" " Spring.....	03
204333	12309	" " " Guard.....	08
200581h	12309	" " " Screw.....	02
204277	12309	" " " Stop.....	15
204278	12309	" " " Driving Gear...	10
200319c	12309	" " " " Gear Hinge Screw	04
200435e	12309	" " " " Screw.....	03
204279	12309	" " " Stud with 204925.....	10
200366h	12309	" " " Set Screw.....	02
204925	12306	" " " " Washer.....	01
205987	12309	Thread Controller complete, Nos. 200300h, 200581h, 202084, 202098, 204274, 204275 and 204333	40
204280	12309	Thread Controller and Spring complete, Nos. 204276 and 205987	45

From the library of Highland Needle Corp.

No.	Plate	Name	Each
202413	12310	Thread Guide.....	05
204281	12309	" Retainer Guide Wire.....	01
202091	12309	" " Sleeve.....	05
202092	12309	" " Spring.....	01
204058B	12309	" " Stud.....	07
200368H	12309	" " " Set Screw.....	02
204059	12309	Thread Retainer complete, Nos. 202091, 202092 and 204058B	15
211077	12314	Throat Plate (formerly "A") 50 needle hole, for needle sizes 3 to 5, for 203253 and 211079.....	60
202062	12308	Throat Plate Position Pin.....	01
200577H	12311	" " Screw (2).....	02

ACCESSORIES

No.	Plate	Name	Each
200157H	12314	Attachment Screw.....	05
226998	12302	Bed Slide (back) with 200798C.....	25
203208	12312	Bobbin (5).....	05
225497	12311	" Case Screw Driver.....	10
225501	12311	Cloth Guide.....	10
200798E	12306	" " Screw Stud.....	01
201556A	12314	" " " " Thumb Nut.....	16
227000	----	Bed Slide (back) complete, Nos. 201556A, 225501 and 226998	60
12 x 3	----	Needles, three each sizes 3 and 4 per doz.	20
227493	12315	Bed Hinge Plate 202259 with two wood screws $\frac{1}{2}$ in. No. 13H	08
225608	----	Drip Pan (long) with four wood screws $\frac{1}{2}$ in. No. 5	30
200748H	12319	Machine Clamp Screw.....	10
201582B	12319	" " " Wing Nut.....	08
225585H	12319	" " " Washer.....	02
227488	12315	Machine Clamp complete, Nos. 200748H, 201582B and 225585H	20
41400	12315	Machine Rest Pin (wood).....	01
225500	12315	Oiler with 225499.....	10
225499	12315	" Spout, 23 in. long.....	02
225498	12315	Screw Driver, $7\frac{1}{4}$ in. long.....	15
225554	12315	Wrench (steel).....	10

ACCESSORIES—(Continued)

BOBBIN WINDER

SWING AUTOMATIC RIGHT HAND

No.	Plate	Name	Each
202470	12320	Bobbin Winder Base.....	15
202471	12320	" " Frame.....	15
200221E	12319	" " " Hinge Screw.....	12
202472	12319	" " " Spring.....	05
200161E	12319	" " " " Screw.....	01
202473	12320	" " Pulley with 200380C.....	20
200380C	12319	" " " Set Screw.....	02
202474	12320	" " Spindle.....	15
227522	12319	" " Stop Latch.....	10
200056E	12319	" " " Screw.....	03
202477	12319	" " " " Thumb Lever.....	15
200299H	12319	" " " " " Lever.....	05
200299H	12319	" " " " " Hinge Screw.....	05
201537H	12319	" " " " " Joint Screw.....	05
202478	12319	" " " " " Thumb Lever.....	10
200299H	12319	" " " " " " Hinge Screw.....	05
227523	12320	Bobbin Winder complete, Nos. 200056E, 200161E, 200221E, 201537H, 202470 to 202474, 202477, 202478, 227522, three 200299H and two round head wood screws $1\frac{1}{2}$ in. No. 11.....	1 35
202480	12320	Bobbin Winder Spool Holder Base with 200355H and 202481.....	15
202481	12320	" " " " Holder Base Spool Pin, for 202485	05
202482	12319	" " " " Holder Tension Disc (lower or upper)	02
200011E	12319	" " " " Spool Holder Tension Screw	05
200355H	12319	" " " " " " Disc Screw Set Screw	03
202483	12319	" " " " " Tension Disc Spring (brass)	01
202484	12319	" " " " " Tension Disc Thread Guide	01
202485	12320	Bobbin Winder Spool Holder complete, Nos. 200011E, 202480, 202481, 202483, two 202482 and one wood screw $1\frac{1}{2}$ in. No. 13H.....	35
227524		Bobbin Winder and Spool Holder com- plete, Nos. 202485 and 227523	1 65

From the library of: Diamond Needle Corp

ACCESSORIES—(Continued)

KNEE LIFTER PARTS

No.	Plate	Name	Each
202450	—	Knee Lifter Rock Lever with 200522c and 200529c	35
202185	12317	" " " " 202150 with two each 202151 and 202152	50
202867	12317	" " " Lever 202185 with 202614 and 202985	85
202451	12317	" " " " Lug with two wood screws $\frac{7}{8}$ in. No. 13u	05
202452	12319	" " " Lever Lug Hinge Pin	02
202614	12317	" " " " Rod $\frac{5}{8}$ in. long with 202456	06
*202456	—	" " " " " Cap or Oil Guard	
200529c	12319	" " " " " Set Screw	05
202453	12317	" " " " Knee Plate with 200526c	17
202985	—	" " " " " 202453 with 202455	25
202455	12317	" " " " Plate Arm (short)	10
200522c	12319	" " " " " Arm Set Screw	06
200526c	12319	" " " " " Set Screw	05

UNDER DRIVER

WITH BELT SUPPORTING GUARD ADAPTING IT FOR UNIVERSAL USE

No.	Plate	Name	Each
202457	12323	Cone Pulley (grooved) two speed, $3\frac{3}{4}$ in. and $1\frac{1}{4}$ in. diameter with 227553	1 35
25362	12321	" Pulley Ball, size $\frac{3}{8}$ in.	02
204100	12321	" " " Bearing Cup	12
204101	12321	" " " Cap	02
204102	12321	" " " Retaining Spring	05
227553	12323	Cone Pulley Ball Cup complete, Nos. 204100 to 204102 and thirteen 25362	45
202459	12323	Driving Pulley, $7\frac{1}{4}$ in. diameter with 202460 and 204405	75
202460	12323	" " Friction Ring (leather)	05
204405	12321	" " " " Stop Pin	01
227743	—	" Shaft (hollow) with 204109, 204110, 204112 and two 204111	60
202461	12323	" Pulley Shaft 227743 with 204107, 204108 and eleven 25303	00
25303	12321	" " Shaft Ball, size $\frac{1}{4}$ in.	03
204107	12321	" " " " Cup	10
204108	12321	" " " " Cap	02
204109	12322	" " " Oil Plug	01
204110	12322	" " " Oiling Leather	02
204111	12322	" " " " " Pin (leather)	01
204112	12322	" " " " Wick	01
200524c	12321	" " " Set Screw	06
204113	12321	" " " Thimble	10
227731	12323	Frame with 200524c	80
227735	12323	Lever Brake with 200524c, 204122 and two 200374c	35
227736	12323	" " 227735 with 200082b and 227737	60
227737	12323	" " Belt Guard	20
200082b	12321	" " " " Screw	03
204122	12322	" " Leather	05
200374c	12321	" " Set Screw	02
200524c	12321	" " Set Screw	06
204123	12322	" " Spring	05
202463	12323	" (compression) with 204117, two each 200524c and 202845	45
204117	12321	" Compression Plate	10
202845	12321	" " Rivet	01
202464	12323	" Shaft with 202302	20
202302	12321	" " Cotter Pin	01
200524c	12321	" " Set Screw	06

From the library of: Diamond Needle Corp

UNDER DRIVER—(Continued)

No.	Plate	Name	Each
204130	12323	Shaft Pulley (sectional grooved) 10 in. diameter, 1 $\frac{1}{2}$ in. bore with two 200008c	45
200008c	12321	Shaft Pulley Clamping Screw	07
202466	12323	Treadle (right) with 200526c	45
227351	12323	" 202466 with 202467	60
202467	12323	" Adjustable Connecting Rod	15
200526c	12321	" " " Rod Set Screw	05
204125	12323	" Pitman Rod (lower) with 202302	05
202302	12321	" " " (lower) Cotter Pin	01
202468	12323	" " " (upper)	05
204126	12321	" " " Clamp with two 200530c	20
200530c	12321	" " " " Set Screw	05
202469	12323	Treadle Pitman complete, Nos. 202468, 204125 and 204126	30
204127	12323	" Stand (left) with two wood screws 1 in. No. 13	08
204128	12323	" " (right) with two wood screws 1 in. No. 13	08
202495	----	Treadle and Stand complete, Nos. 204127, 204128 and 227351	75
202496	----	Treadle and Pitman complete, Nos. 202469 and 202495	90
227738	----	Transmitter complete, (formerly "Serial 54400") Nos. 202457, 202459, 202461, 202463, 202464, 204113, 204123, 227734, 227736 and three wood screws 1 $\frac{1}{2}$ in. No. 15	3 00
227739	12323	Under Driver (ball bearing) lever pressure, right hand, two speed, complete, Nos. 202496, 204130 and 227738	4 00

NUMERICAL LIST OF PARTS

No.	Plate	Name	Each
25303	12321	Under Driver Driving Pulley Shaft Ball, size $\frac{1}{2}$ in., for 202461	03
25362	12321	" Driver Cone Pulley Ball, size $\frac{1}{2}$ in., for 227553	02
41400	12315	Machine Rest Pin (wood)	01
200002c	12310	Feed Driving Cam Fork lever Connection Hinge Screw, for 200554	07
200006c	12307	Hook Saddle Screw	07
200008c	12321	Under Driver Shaft Pulley Clamping Screw, for 204130	07
200011c	12319	Bobbin Winder Spool Holder Tension Disc Screw, for 202485	05
200016c	12311	Arm Screw	06
200027c	12310	Feed Lifting Cam Fork Pinch Screw for 204202	04
200031c	12311	Feed Driving Cam Fork lever Connection Clamp Pinch Screw, for 204191	04
200042c	12311	Take-up Lever Bearing Screw, for 203271	05
200043c	12311	Feed Driving Cam Fork-lever Shaft Sleeve Set Screw	01
200043c	12311	" " Rock Shaft Center Set Screw	04
200043c	12311	" Lifting Rock Shaft Center Set Screw	01
200045c	12310	" " Cam Screw, for 213454	03
200053c	12311	Face Plate Screw	01
200054c	12307	Arm Shaft Connection Cap Screw, for 204165	03
200056c	12319	Bobbin Winder Stop Latch Screw, for 227523	03
200062c	12311	Balance Wheel Adjusting Screw	07
200072c	12308	Needle Bar Connecting Stud Pinch Screw, for 204249	03
200074c	12308	Presser Foot Screw, for 204251	03
200078c	12307	Feed Regulating Handle Shaft Crank Set Screw, for 204211	03
200079c	12311	Spool Holder Wire Hinge Screw, for 204297	02
200082b	12321	Under Driver Lever Brake Belt Guard Screw, for 227736	03
200086c	12308	Presser Bar Lifting Bracket Pinch Screw, for 204253	03
200098c	12307	Feed Regulating Handle Adjustable Stop Screw, for 204207	03
200106c	12311	Feed Dog Screw, for 229799	02

PLATE 12301--ONE-FOURTH SIZE

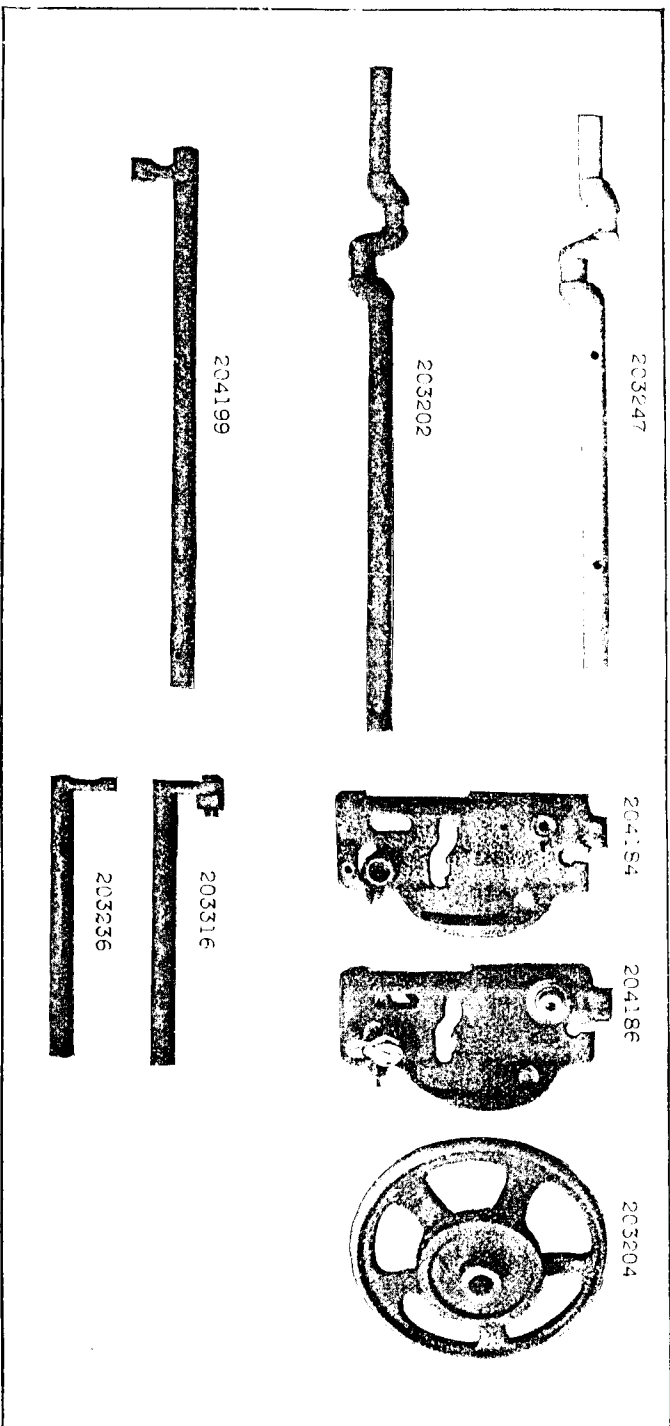

PLATE 12302 ONE-HALF SIZE

204193



203218



203243



204165



226998

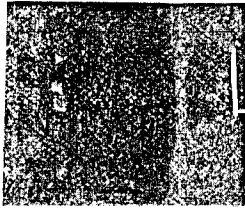

203206

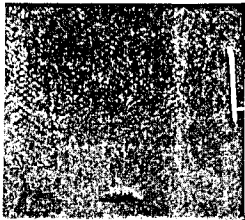

203207



PLATE 12304 ONE-HALF SIZE

204247



204251



204705



203268



203248



204198



204207



From the library of: Diamond Needle Corp

PLATE 12305 - FULL SIZE

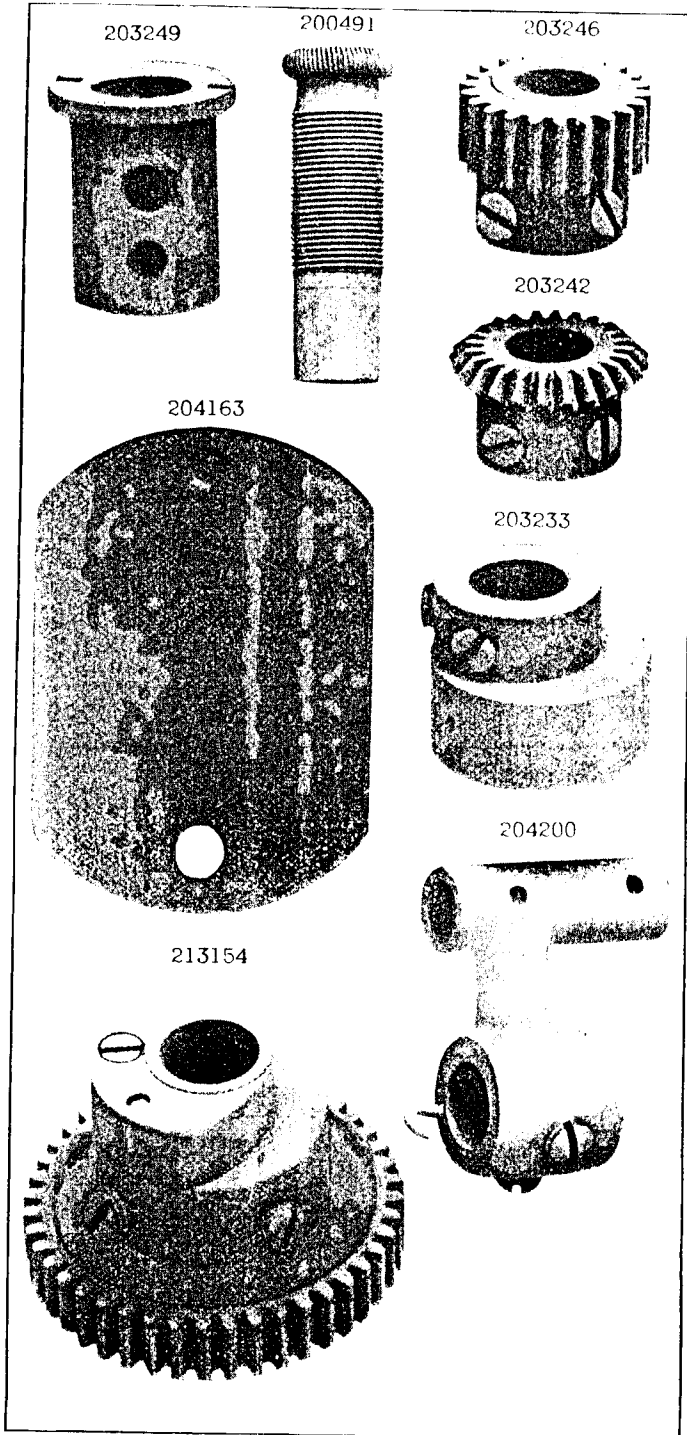
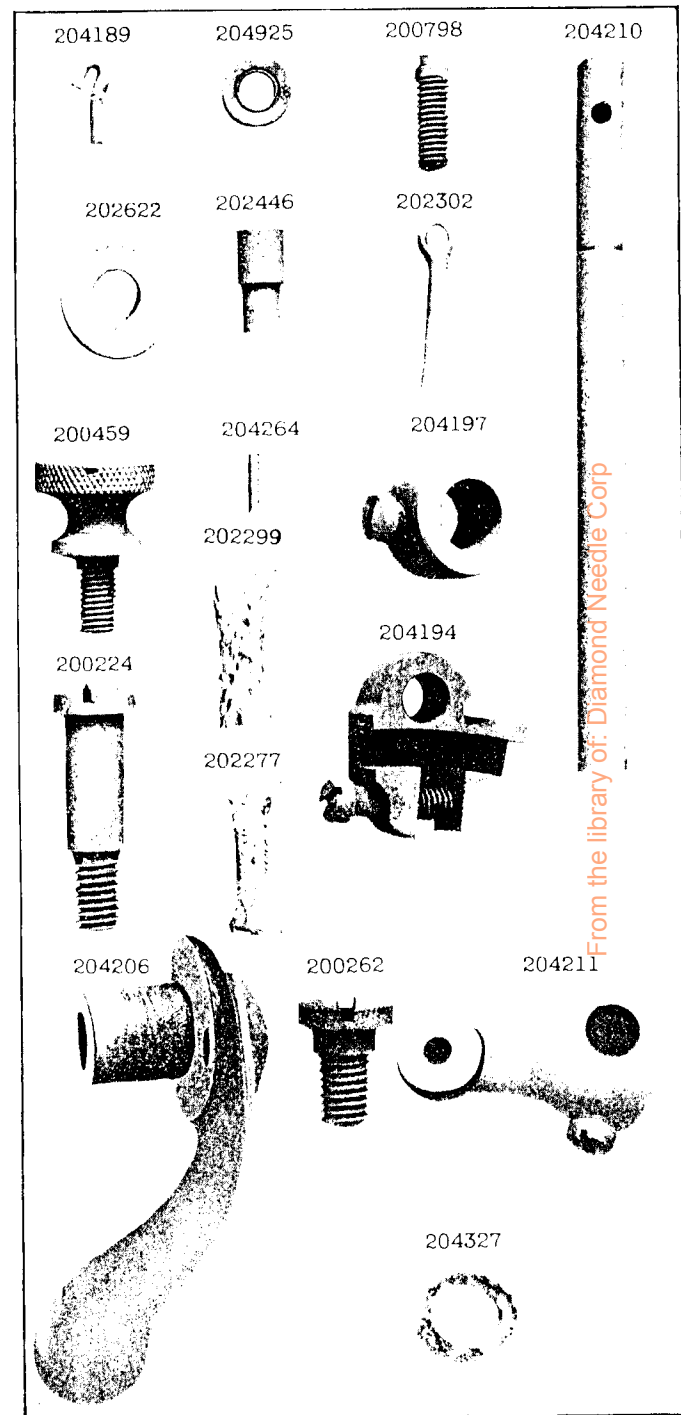

PLATE 12306 - FULL SIZE



From the library of: Diamond Needle Corp

PLATE 12307 - FULL SIZE

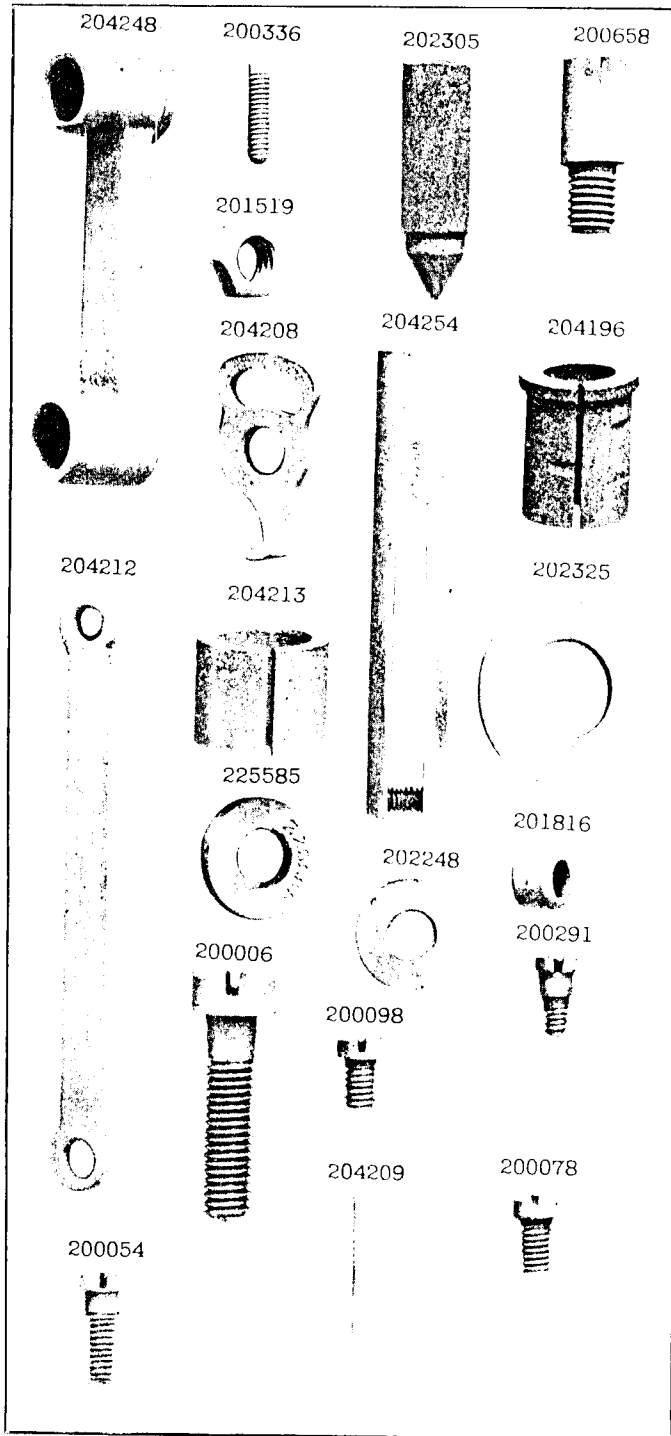
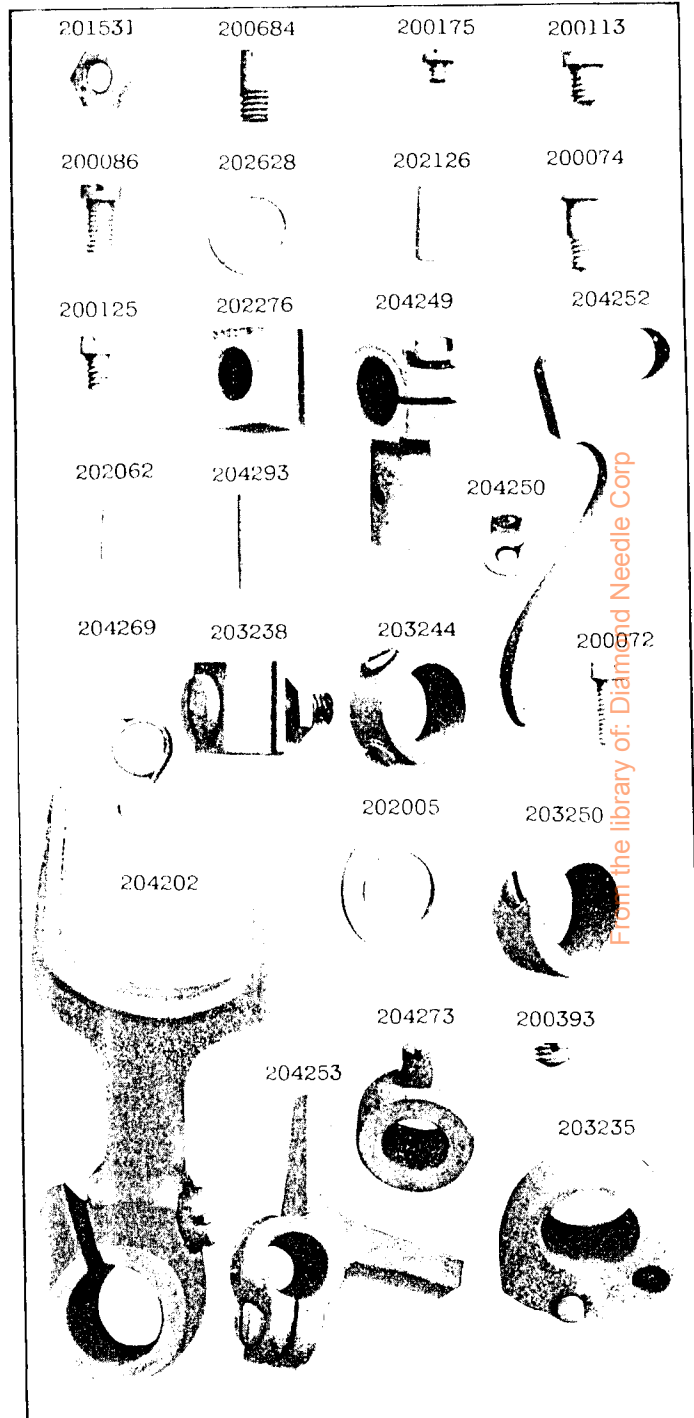

PLATE 12308 - FULL SIZE



From the library of: Diamond Needle Corp

PLATE 12309 FULL SIZE

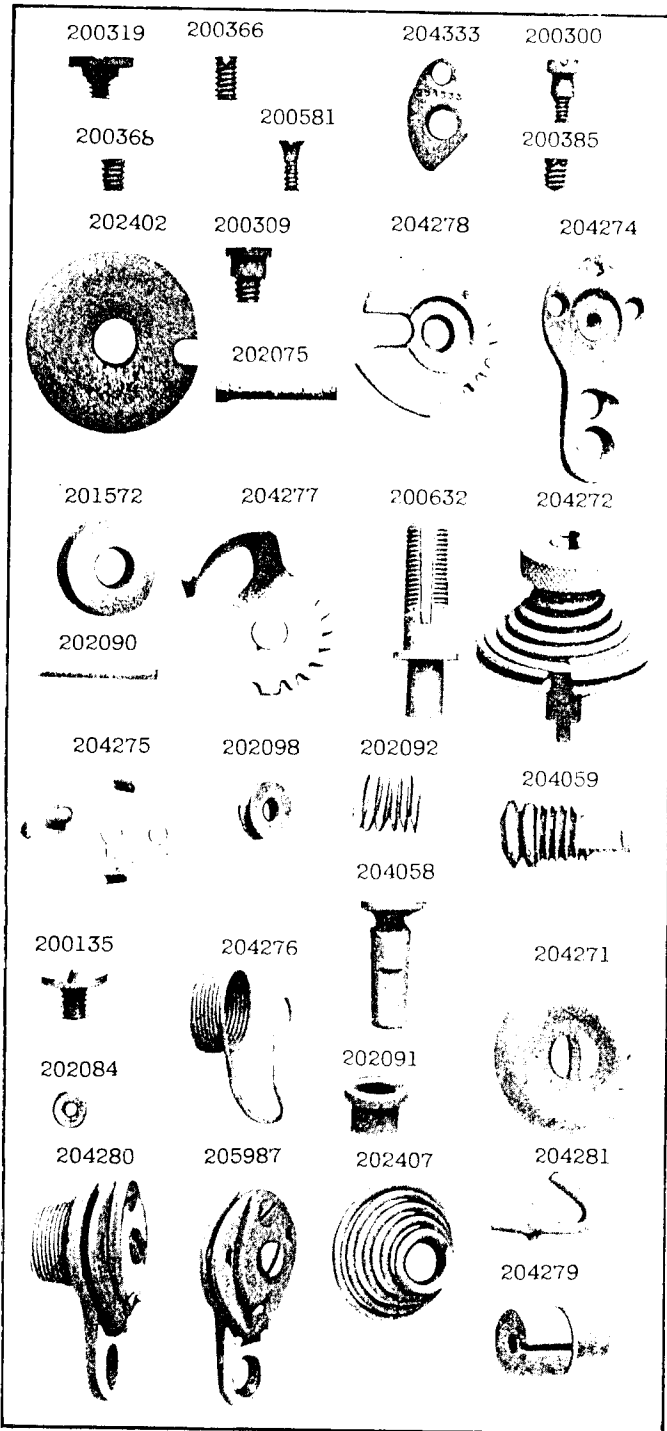
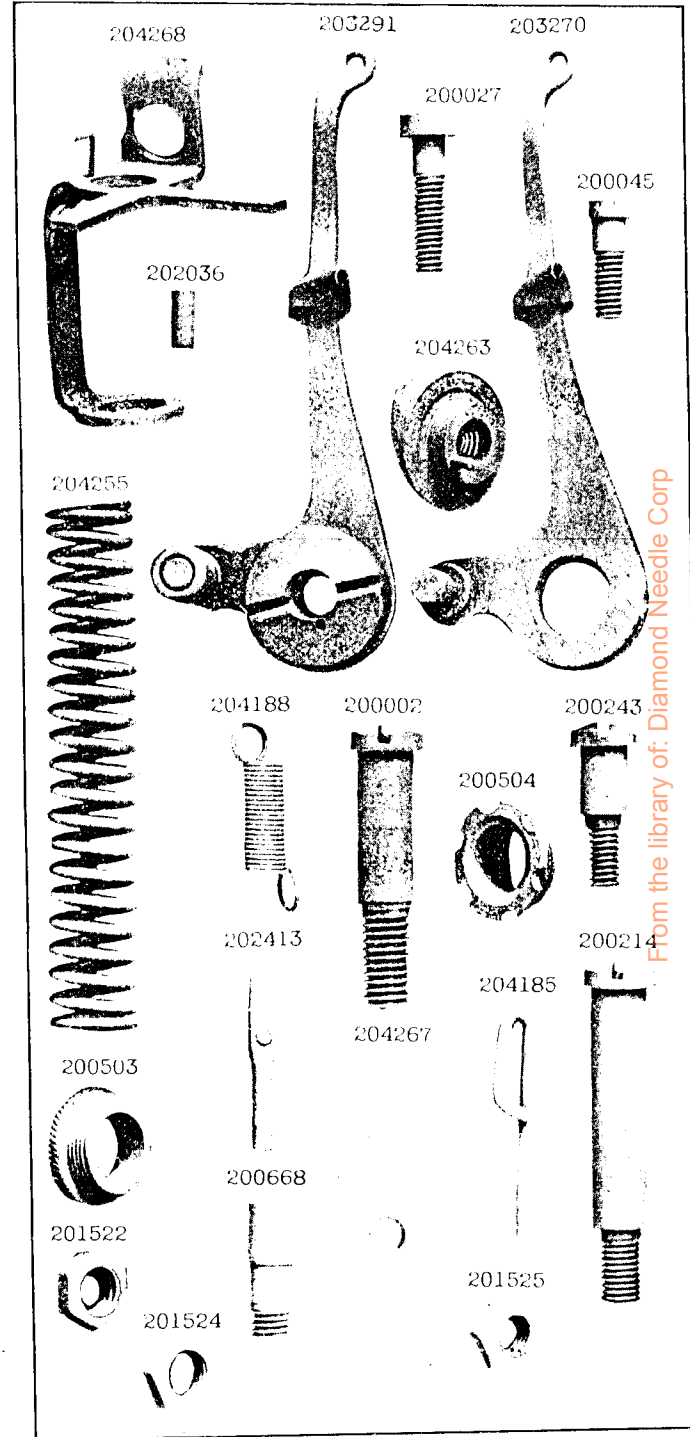

PLATE 12310-FULL SIZE



From the library of: Diamond Needle Corp

PLATE 12311-FULL SIZE

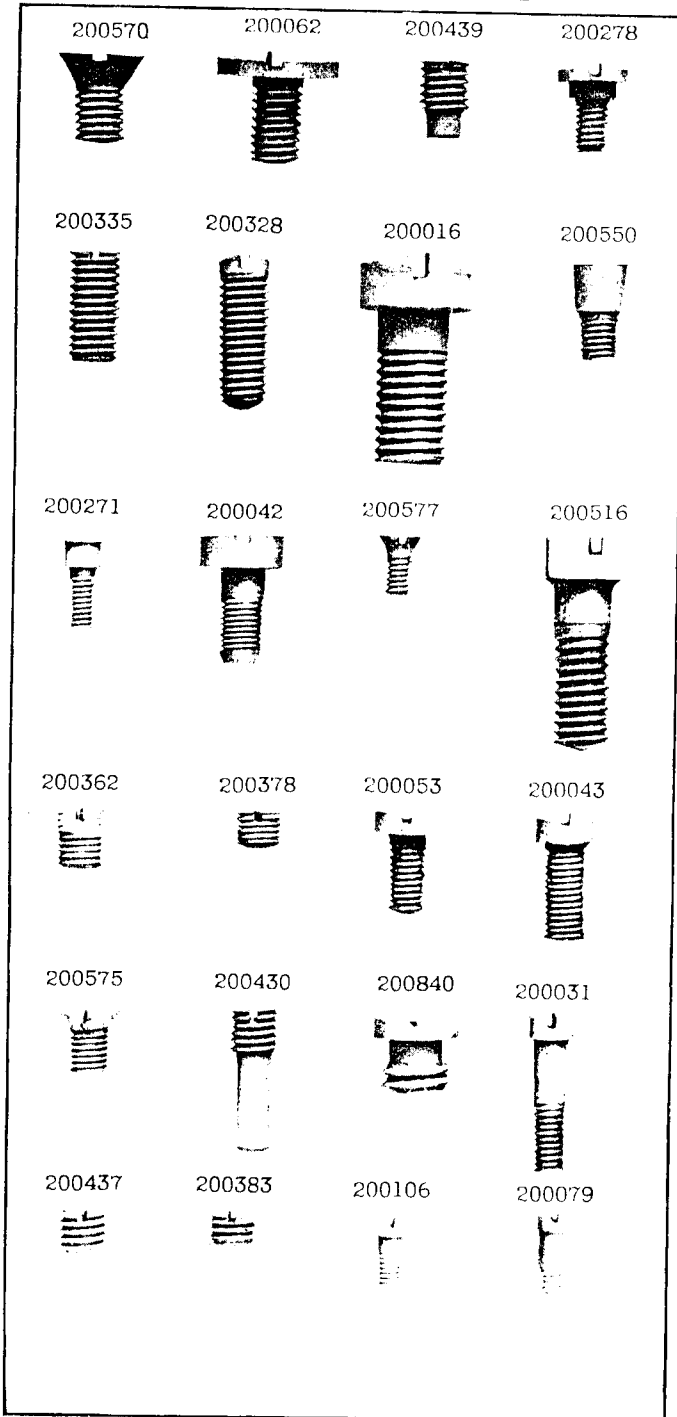
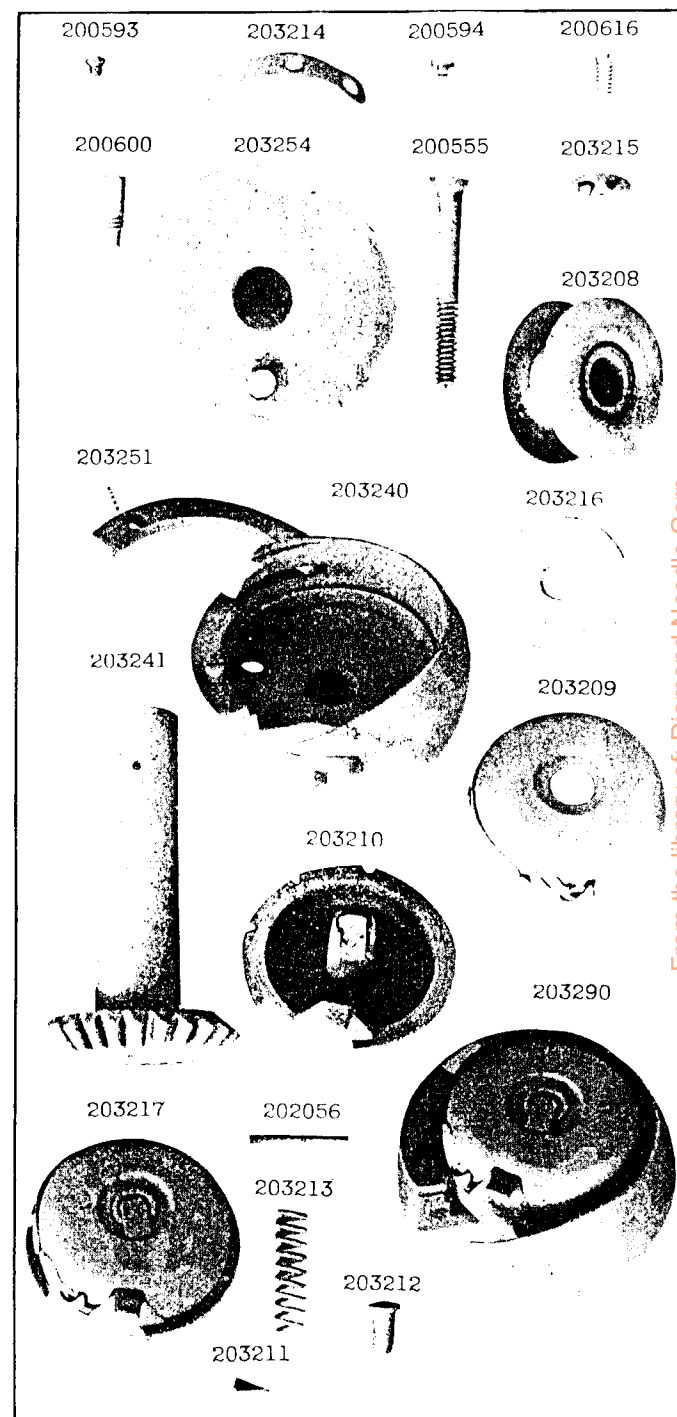

PLATE 12312-FULL SIZE



From the library of Diamond Needle Corp.

PLATE 12313—FULL SIZE

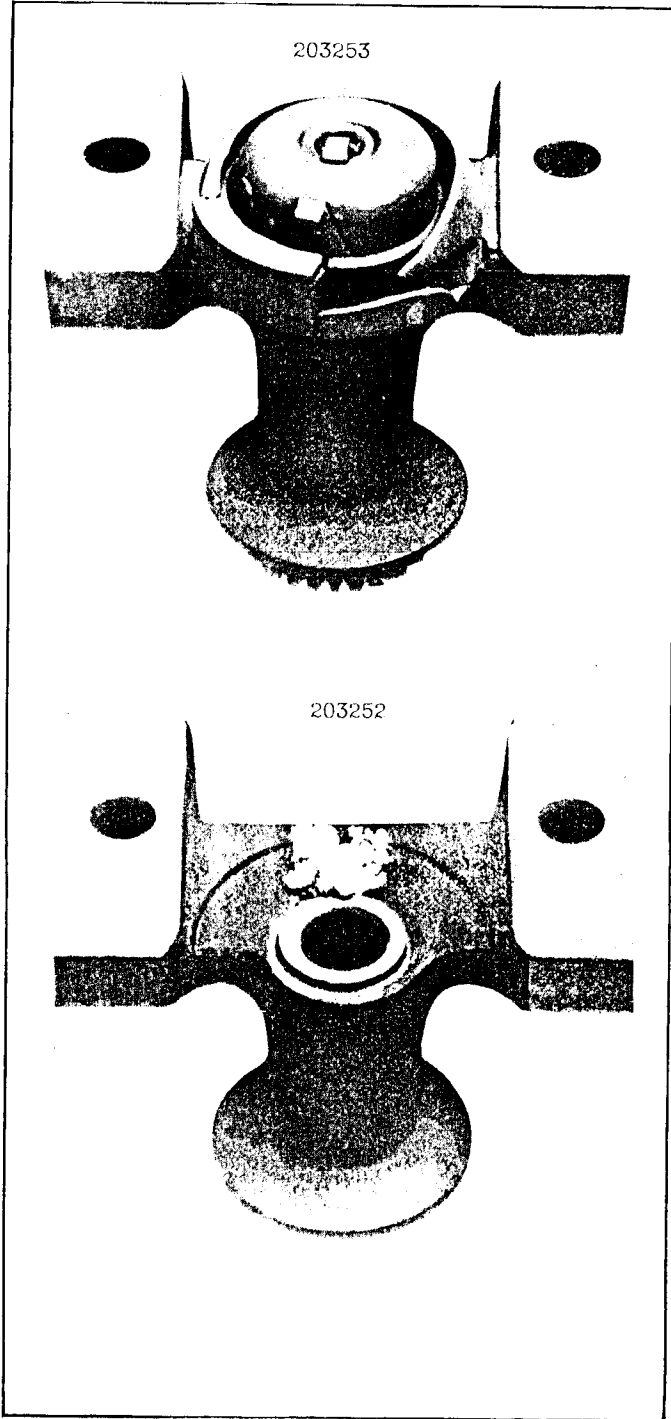
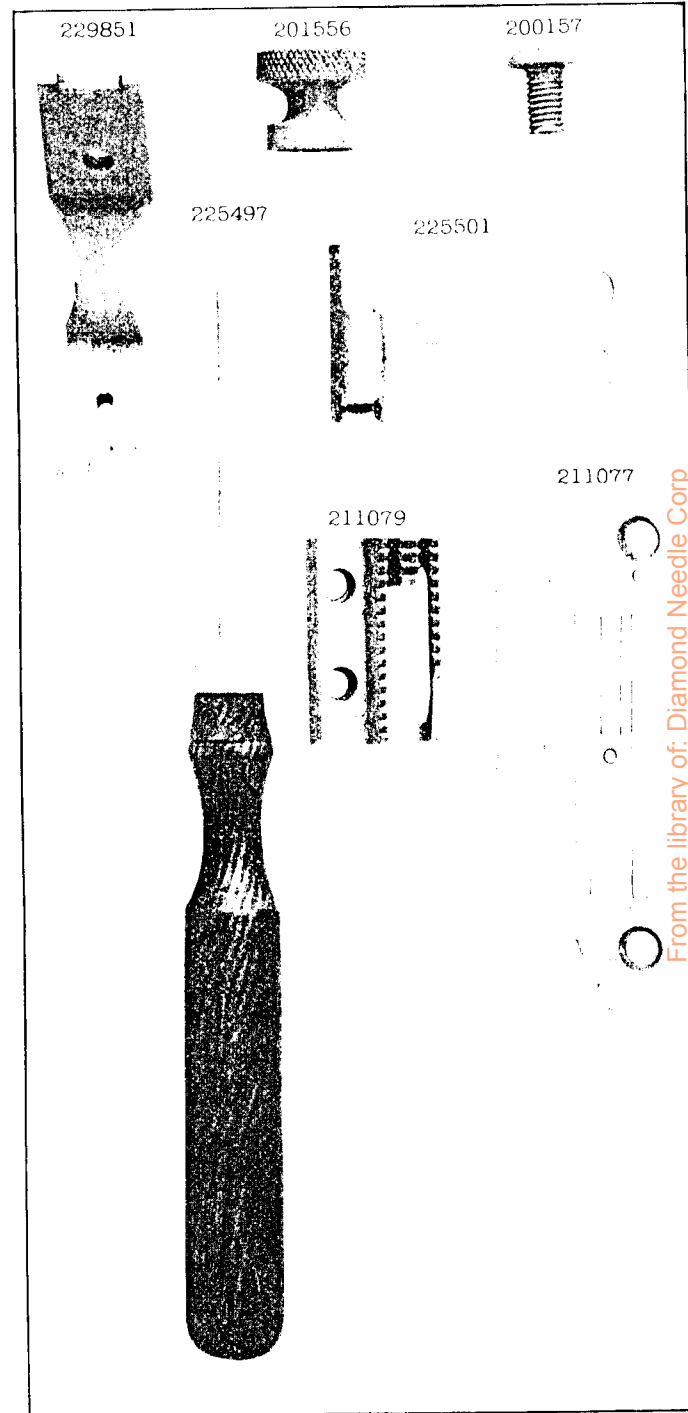

PLATE 12314—FULL SIZE



From the library of: Diamond Needle Corp

PLATE 12315 ONE-HALF SIZE

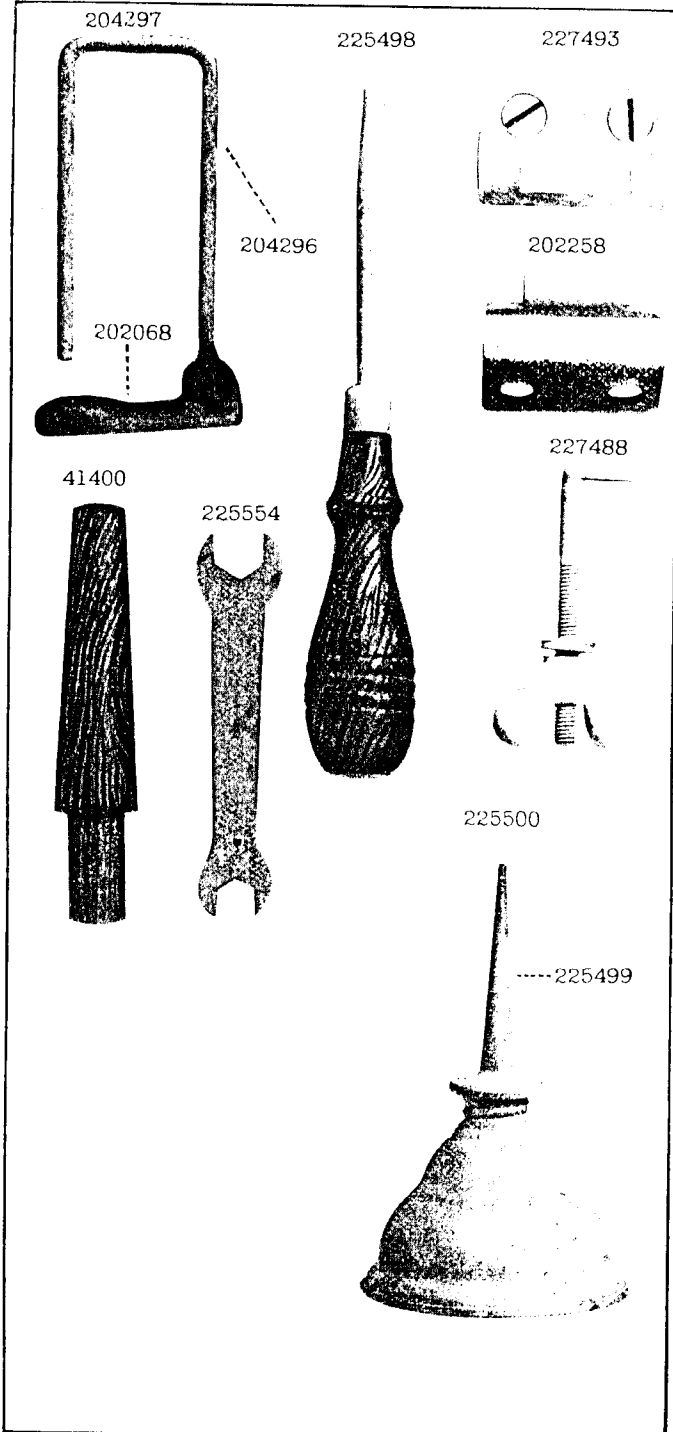
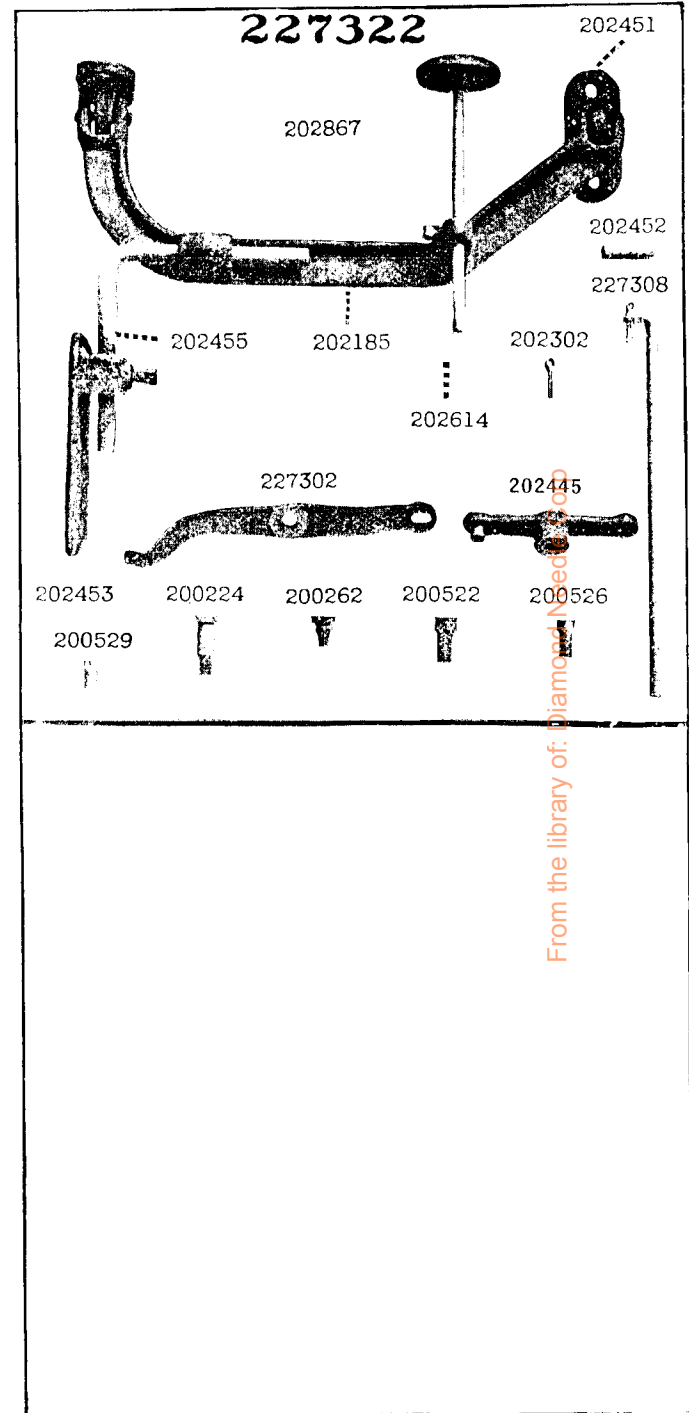

PLATE 12317 ONE-FOURTH SIZE



From the library of: Diamond Need

PLATE 12319 - FULL SIZE

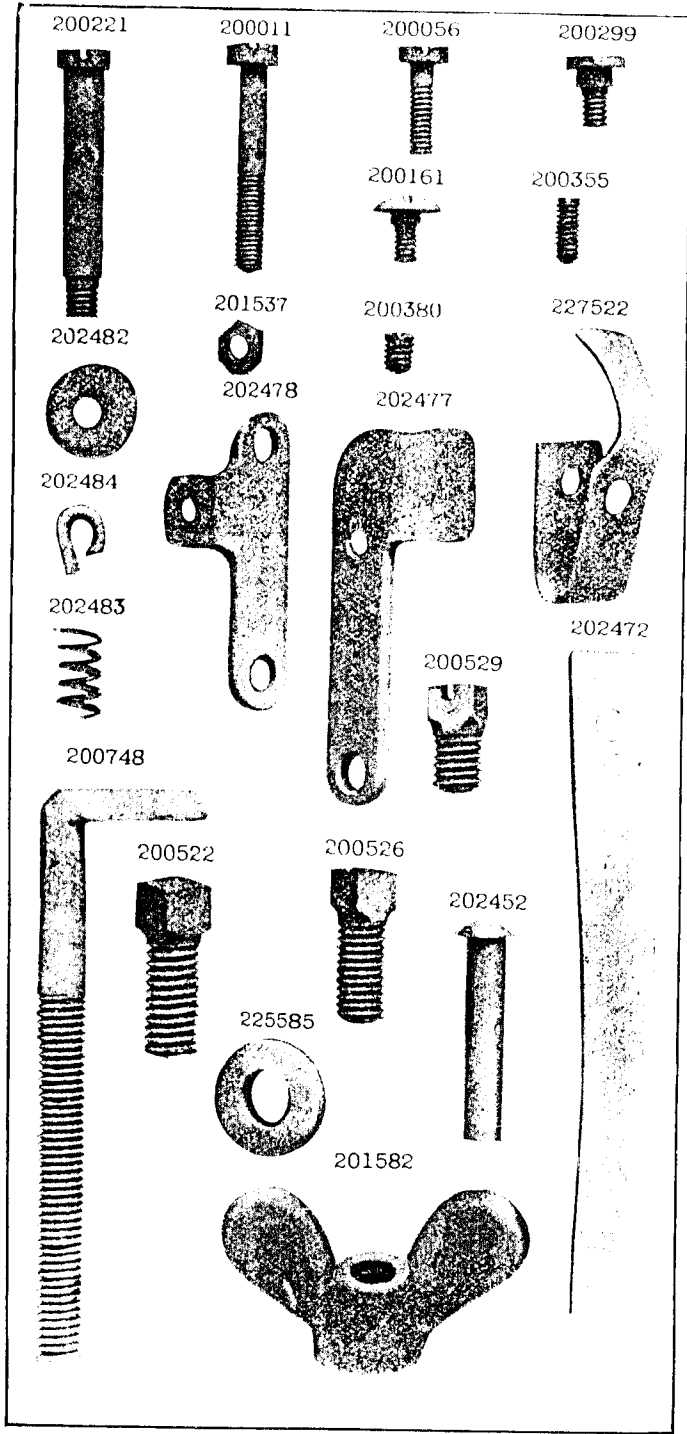
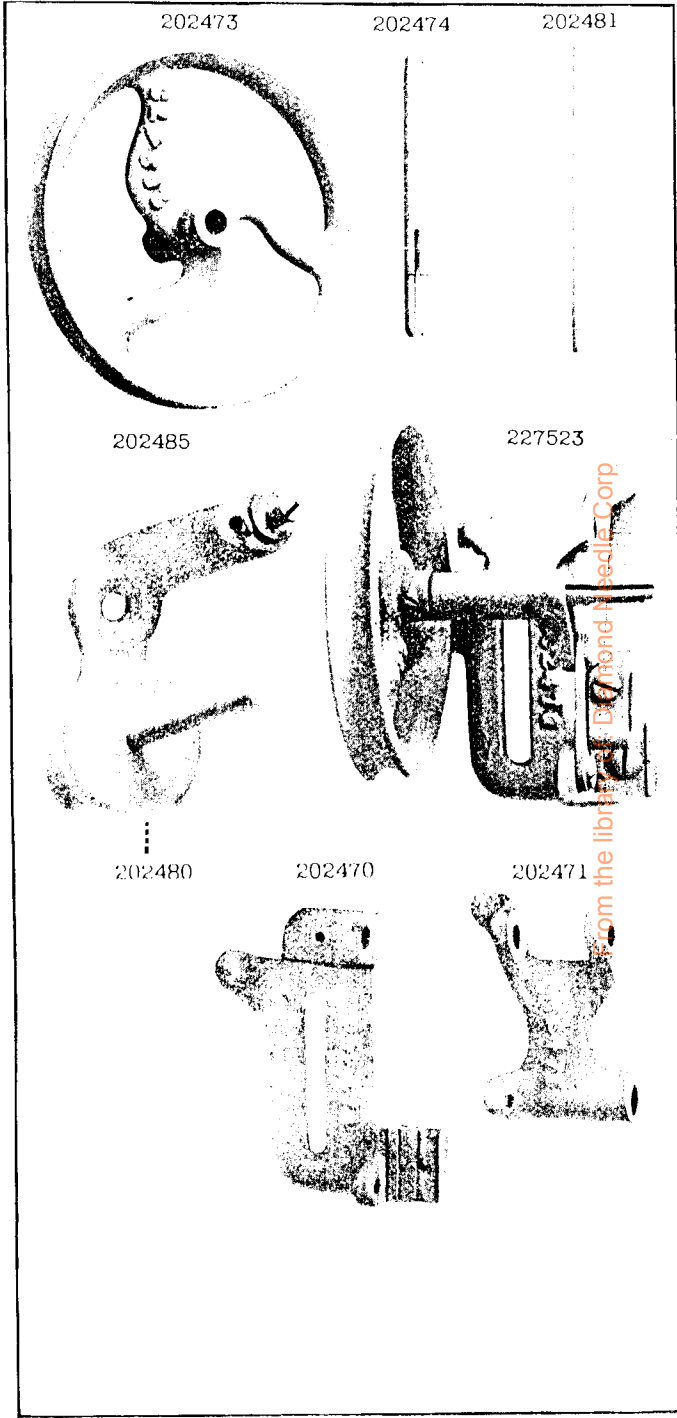

PLATE 12320 - ONE-HALF SIZE



from the library of Biond-Breda Corp.

PLATE 12321--FULL SIZE

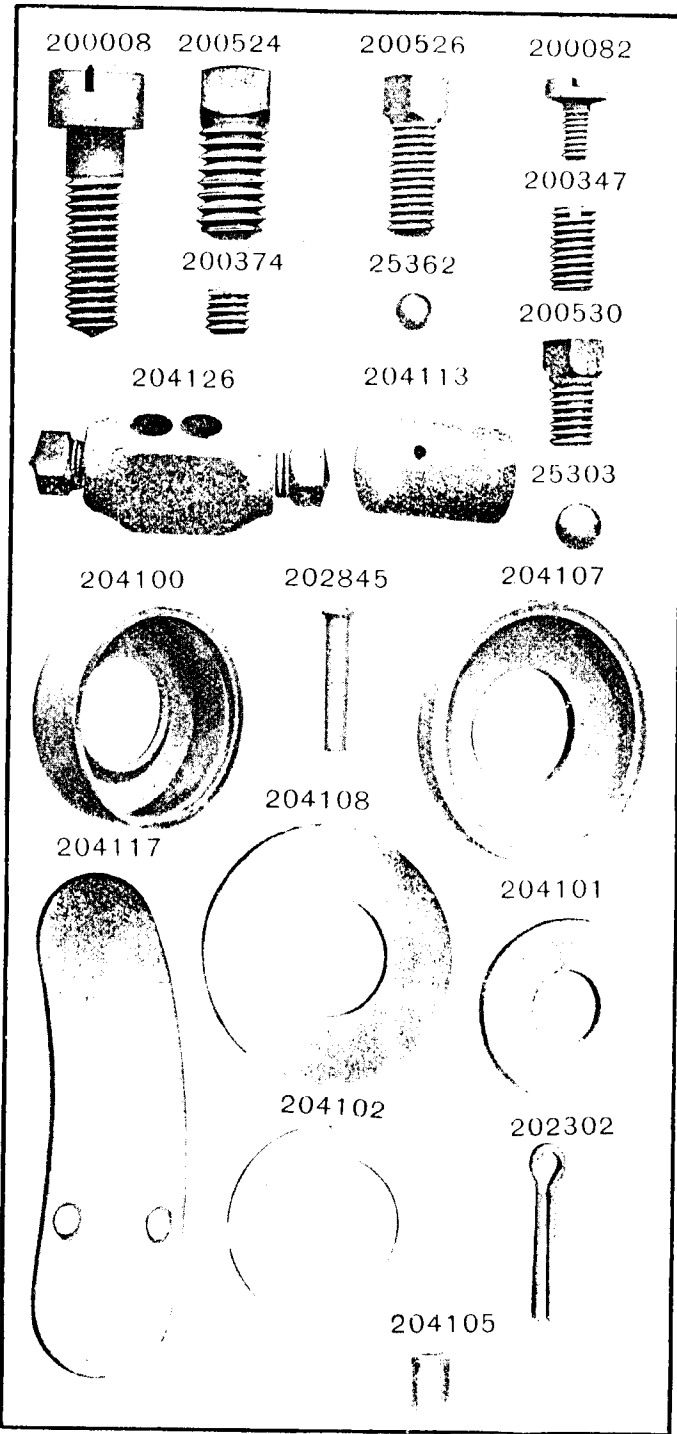
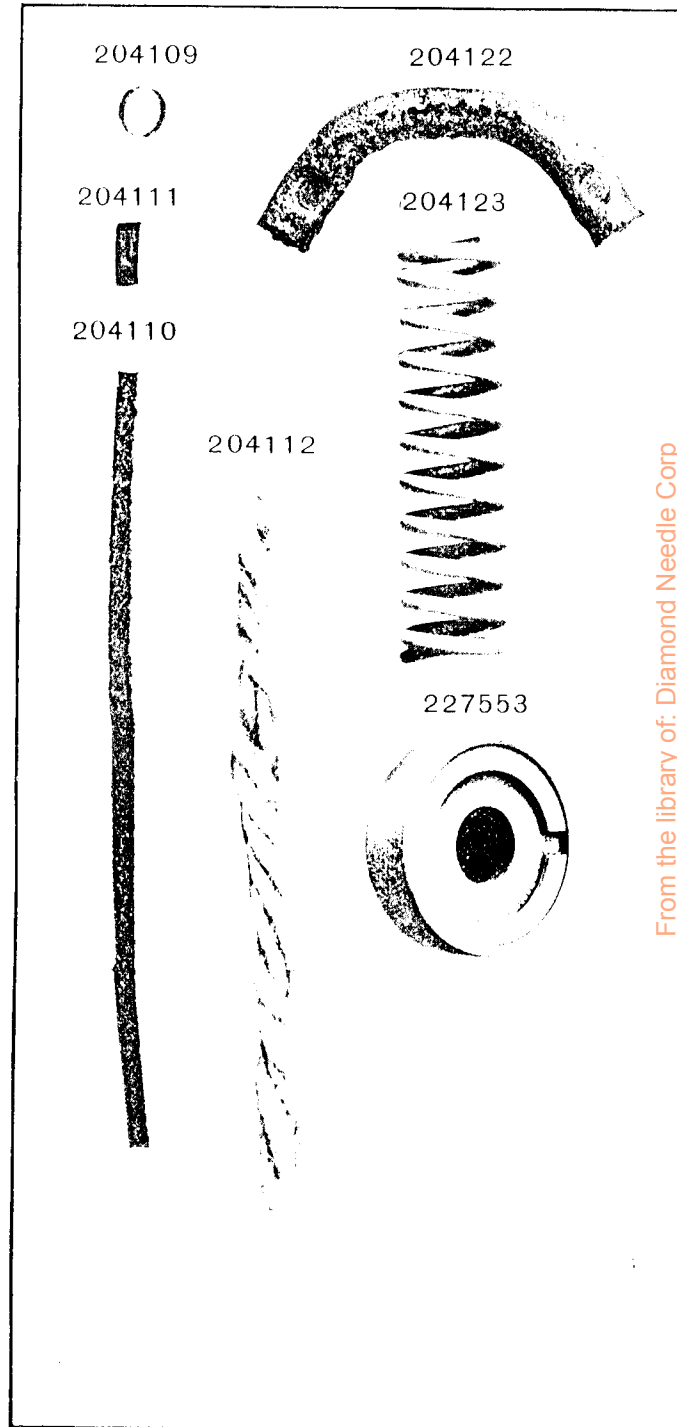

PLATE 12322--FULL SIZE



From the library of: Diamond Needle Corp

PLATE 12323-ONE-SIXTH SIZE

